

# ASAHWO

## Model:PD22SA

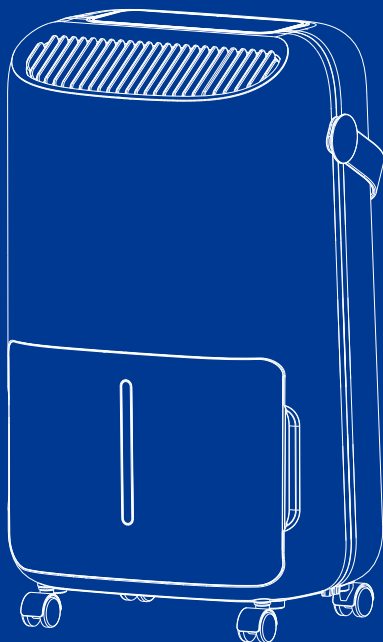

Thank you for your order.  
You made our day.

Thanks for your purchase.  
If any problems with our dehumidifier, please feel free to contact us

Please refer to the model on the nameplate of the machine.  
Please read the user manual carefully before use and keep it properly.

[Email:support@asahwo.com](mailto:support@asahwo.com)



# Instructions for Use:

**1. Dehumidification Capacity**-The dehumidification capacity of the dehumidifier is related to the humidity and temperature of the area where it is used. And the 45 pint is not mean the capacity of the water tank but mean the dehumidification capacity in 24h in 90°F and 90%RH.

**2. Turn the machine on and Off**-when the ambient temperature reaches the set humidity of the dehumidifier, the machine will stand by.

When the ambient humidity is higher than the set humidity of the machine again, the machine will start working again.

If the humidity of the dehumidifier is inconsistent with the humidity you measured, it is mainly due to the inconsistency of the measurement location or the inconsistency of the evaluation method of the hygrometer and the dehumidifier.

**3. Stop when the water tank is full**-when the water tank is full, the machine will stop. If it is full, please empty the water tank and reinstall the water tank, and the machine will start working again. If the water is full, the machine will stop.

Please make sure that the machine is placed smoothly.

Please check whether the water tank is installed and whether the induction magnet of the water tank is still there.

**4. Timing Setting**-The dehumidifier can be turned on and off regularly.

Start the machine regularly: After the machine is plugged into the power supply, press the "TIMER" button to set the machine startup time. Timing shutdown:

When the machine is plugged in, press the power-on button and then Press the "TIMER" button to set the shutdown time.





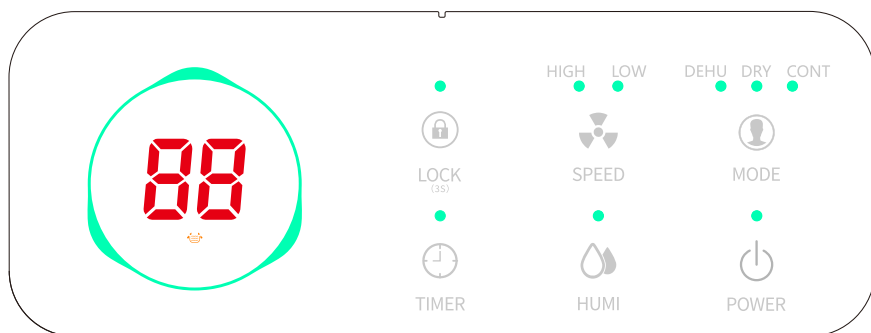

If you encounter problems, please contact our customer service. We will serve you.

[Email:support@asahwo.com](mailto:support@asahwo.com)

<http://www.asahwo.com>



## ■ Key Description

|  |  |   |  |
|--|--|---|--|
|  | <p><b>Child lock key</b><br/>For activation and deactivation of the child lock function.</p> |  | <p><b>Humidity key</b><br/>For setting the humidity level.</p> |
|  | <p><b>Fan speed key</b><br/>To switch the fan speeds.</p>                                    |  | <p><b>Mode key</b><br/>To choose the working mode.</p>         |
|  | <p><b>Timing key</b><br/>To set the time on the device, the setting range is 1~24h.</p>      |  | <p><b>Power button</b><br/>To turn the machine on/off.</p>     |

# CONTENTS

|   |    |
|---|----|
| <b>WARNING FOR R290</b> .....                 | 01 |
| <b>IMPORTANT SAFETY INSTRUCTIONS</b> .....    | 15 |
| • Warning .....                               | 15 |
| • How to Use a Dehumidifier Effectively ..... | 16 |
| <b>MACHINE CONSTRUCTION</b> .....             | 18 |
| • Mainframe .....                             | 18 |
| <b>OPERATION INSTRUCTION</b> .....            | 19 |
| • Key Description .....                       | 19 |
| • Function Set .....                          | 20 |
| • Precautions .....                           | 22 |
| • Drain Indication .....                      | 22 |
| • Use of the Water Tank .....                 | 22 |
| • Empty the Water Tank .....                  | 23 |
| • Continuous Drainage .....                   | 23 |
| • Filter Cleaning .....                       | 24 |
| • Fault Phenomenon .....                      | 25 |
| <b>SAFETY PRECAUTIONS</b> .....               | 26 |
| <b>SPECIFICATIONS</b> .....                   | 27 |
| <b>Limited Warranty</b> .....                 | 28 |

# 01 WARNING FOR R290

## Warning for Using R290 Refrigerant:

Transportation, marking and storage for units that employ flammable refrigerants

### 1.General

The following information is provided for units that employ flammable refrigerants.

### 2.Transport of equipment containing flammable refrigerants

Attention is drawn to the fact that additional transportation regulations may exist with respect to equipment containing flammable gas. The maximum number of pieces of equipment or the configuration of the equipment permitted to be transported together will be determined by the applicable transport regulations.

### 3.Marking of equipment using signs

Signs for similar appliances used in a work area are generally addressed by local regulations and give the minimum requirements for the provision of safety and/or health signs for a work location.

All required signs are to be maintained and employers should ensure that employees receive suitable and sufficient instruction and training on the meaning of appropriate safety signs and the actions that need to be taken in connection with these signs.

The effectiveness of signs should not be diminished by too many signs being placed together.

Any pictograms used should be as simple as possible and contain only essential details.

### 4.Disposal of equipment using flammable refrigerants

See national regulations.

### 5.Storage of equipment/appliances

The storage of the appliance should be in accordance with the applicable regulations or instructions, whichever is more stringent.

### 6.Storage of packed (unsold) equipment

Storage package protection should be constructed in such a way that mechanical damage to the equipment inside the package will not cause a leak of the refrigerant charge .

The maximum number of pieces of equipment permitted to be stored together will be determined by local regulations.

## VERY IMPORTANT !

Please do not install or use your equipment before you have carefully read this manual. Please keep this instruction manual for an eventual product warranty and for future reference.

## Requirements for operation, service and installation manuals of appliances using flammable refrigerants

### Warning

Do not use means to accelerate the defrosting process or to clean, other than those recommended by the manufacturer.

The appliance shall be stored in a room without continuously operating ignition sources for example:

open flames, an operating gas appliance or an operating electric heater.

Do not pierce or burn.

Be aware that refrigerants may not contain an odour.



Appliance filled with flammable gas as R290.

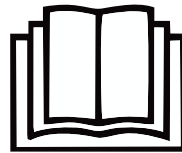

Before use the appliance, read the owner's manual first.

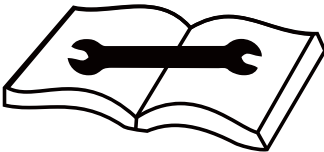

Before repair the appliance, read the service manual first.

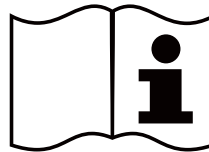

Before install the appliance, read the installation manual first.

## Qualification of workers

The manual shall contain specific information about the required qualification of the working personnel for maintenance, service and repair operations. Every working procedure that affects safety means shall only be carried out by competent persons. Examples for such working procedures are:

- breaking into the refrigerating circuit;
- opening of sealed components;
- opening of ventilated enclosures.

## Competence of service personnel

### 1.General

Information of procedures additional to usual information for refrigerating appliance installation, repair, maintenance and decommission procedures is required when an appliance with flammable refrigerant is affected.

The training of these procedures is carried out by national training organisations or manufacturers that are accredited to teach the relevant national competency standards that may be set in legislation.

The achieved competence should be documented by a certificate.

### 2.Information and trainin

2.1) The training should include the substance of the following:

2.2) Information about the explosion potential of flammable refrigerantsto show that flammables may be dangerous when handled without care.

2.3) Information about potential ignition sources, especially those that are not obvious such as lighters, light switches, vacuum cleaners, electric heaters.

#### 2.4) Information about the different safety concepts:

Unventilated-Safety of the appliance does not depend on ventilation of the housing. Switching off the appliance or opening of the housing has no significant effect on the safety. Nevertheless, it is possible that leaking refrigerant may accumulate inside the enclosure and flammable atmosphere will be released when the enclosure is opened. Ventilated enclosure-Safety of the appliance depends on ventilation of the housing. Switching off the appliance or opening of the enclosure has a significant effect on the safety. Care should be taken to ensure sufficient ventilation before. Ventilated room -Safety of the appliance depends on the ventilation of the room. Switching off the appliance or opening of the housing has no significant effect on the safety. The ventilation of the room shall not be switched off during repair procedures.

#### 2.5) Information about refrigerant detectors:

- Principle of function, including influences on the operation.
- Procedures, how to repair, check or replace a refrigerant detector or parts of it in a safe way.
- Procedures, how to disable a refrigerant detector in case of repair work on the refrigerant carrying parts.

2.6) Information about the concept of sealed components and sealed enclosures --- according to IEC60079-15:2010.

#### 2.7) Information about the correct working procedures:

##### **a) Commissioning**

- Ensure that the floor area is sufficient for the refrigerant charge or that the ventilation duct is assembled in a correct manner.
- Connect the pipes and carry out a leak test before charging with refrigerant.
- Check safety equipment before putting into service.

## **b) Maintenance**

- Portable equipment shall be repaired outside or in a workshop specially equipped for servicing units with flammable refrigerants.
- Ensure sufficient ventilation at the repair place.
- Be aware that malfunction of the equipment may be caused by refrigerant loss and a refrigerant leak is possible.
- Discharge capacitors in a way that won't cause any spark. The standard procedure to short circuit the capacitor terminals usually creates sparks.
- Reassemble sealed enclosures accurately. If seals are worn, replace them.
- Check safety equipment before putting into service.

## **c) Repair**

- Portable equipment shall be repaired outside or in a workshop specially equipped for servicing units with flammable refrigerants.
- Ensure sufficient ventilation at the repair place.
- Be aware that malfunction of the equipment may be caused by refrigerant loss and a refrigerant leak is possible.
- Discharge capacitors in a way that won't cause any spark.
- When brazing is required, the following procedures shall be carried out in the right order:

Remove the refrigerant. If the recovery is not required by national regulations, drain the refrigerant to the outside. Take care that the drained refrigerant will not cause any danger. In doubt, one person should guard the outlet. Take special care that drained refrigerant will not float back into the building.

- Evacuate the refrigerant circuit.
- Purge the refrigerant circuit with nitrogen for 5 min (not required for A3L refrigerants).
- Evacuate again (not required for A3L refrigerants).
- Remove parts to be replaced by cutting, not by flame.
- Purge the braze point with nitrogen during the brazing procedure.
- Carry out a leak test before charging with refrigerant.
- Reassemble sealed enclosures accurately. If seals are worn, replace them.
- Check safety equipment before putting into service.

## **d) Decommissioning**

- If the safety is affected when the equipment is putted out of service, the refrigerant charge shall be removed before decommissioning.
- Ensure sufficient ventilation at the equipment location.
- Be aware that malfunction of the equipment may be caused by refrigerant loss and a refrigerant leak is possible.
- Discharge capacitors in a way that won't cause any spark.
- Remove the refrigerant. If the recovery is not required by national regulations, drain the refrigerant to the outside. Take care that the drained refrigerant will not cause any danger. In doubt, one person should guard the outlet. Take special care that drained refrigerant will not float back into the building.
- When flammable refrigerants except A3L refrigerants are used.
  - Evacuate the refrigerant circuit.
  - Purge the refrigerant circuit with nitrogen for 5 min.
  - Evacuate again.
  - Fill with nitrogen up to atmospheric pressure.
  - Put a label on the equipment that the refrigerant is removed.

## **e) Disposal**

- Ensure sufficient ventilation at the working place.
- Remove the refrigerant. If the recovery is not required by national regulations, drain the refrigerant to the outside. Take care that the drained refrigerant will not cause any danger. In doubt, one person should guard the outlet. Take special care that drained refrigerant will not float back into the building.
- When flammable refrigerants are used.
  - evacuate the refrigerant circuit.
  - purge the refrigerant circuit with oxygen free nitrogen.
  - evacuate again. (not required for A3L refrigerants); and cut out the compressor and drain the oil.

## **Information on servicing**

### **1.General**

The manual shall contain specific information for service personnel according.

### **2.Checks to the area**

Prior to beginning work on systems containing flammable refrigerants, safety checks are necessary to ensure that the risk of ignition is minimised.

For repair to the refrigerating system.

### **3.Work procedure**

Work shall be undertaken under a controlled procedure so as to minimise the risk of a flammable gas or vapour being present while the work is being performed.

### **4.General work area**

All maintenance staff and others working in the local area shall be instructed on the nature of work being carried out. Work in confined spaces shall be avoided.

### **5.Checking for presence of refrigerant**

The area shall be checked with an appropriate refrigerant detector prior to and during work, to ensure the technician is aware of potentially toxic or flammable atmospheres. Ensure that the leak detection equipment being used is suitable for use with all applicable refrigerants, i. e. non-sparking, adequately sealed or intrinsically safe.

### **6.Presence of fire extinguisher**

If any hot work is to be conducted on the refrigerating equipment or any associated parts, appropriate fire extinguishing equipment shall be available to hand. Have a dry powder or CO<sub>2</sub> fire extinguisher adjacent to the charging area.

### **7.No ignition sources**

No person carrying out work in relation to a refrigerating system which involves exposing any pipe work shall use any sources of ignition in such a manner that it may lead to the risk of fire or explosion. All possible ignition sources, including cigarette smoking, should be kept sufficiently far away from the site of installation, repairing, removing and disposal, during which refrigerant can possibly be released to the surrounding space.

Prior to work taking place, the area around the equipment is to be surveyed to make sure that there are no flammable hazards or ignition risks. "No Smoking" signs shall be displayed.

## **8.Ventilated area**

Ensure that the area is in the open or that it is adequately ventilated before breaking into the system or conducting any hot work. A degree of ventilation shall continue during the period that the work is carried out. The ventilation should safely disperse any released refrigerant and preferably expel it externally into the atmosphere.

## **9.Checks to the refrigerating equipment**

Where electrical components are being changed, they shall be fit for the purpose and to the correct specification. At all times the manufacturer's maintenance and service guidelines shall be followed. If in doubt, consult the manufacturer's technical department for assistance.

The following checks shall be applied to installations using

### **FLAMMABLE REFRIGERANTS:**

- the actual refrigerant charge is in accordance with the room size within which the refrigerant containing parts are installed;
- the ventilation machinery and outlets are operating adequately and are not obstructed;
- if an indirect refrigerating circuit is being used, the secondary circuit shall be checked for the presence of refrigerant;
- marking to the equipment continues to be visible and legible. Markings and signs that are illegible shall be corrected;
- refrigerating pipe or components are installed in a position where they are unlikely to be exposed to any substance which may corrode refrigerant containing components, unless the components are constructed of materials which are inherently resistant to being corroded or are suitably protected against being so corroded.

## **10. Checks to electrical devices**

Repair and maintenance to electrical components shall include initial safety checks and component inspection procedures. If a fault exists that could compromise safety, then no electrical supply shall be connected to the circuit until it is satisfactorily dealt with. If the fault cannot be corrected immediately but it is necessary to continue operation, an adequate temporary solution shall be used. This shall be reported to the owner of the equipment so all parties are advised. Initial safety checks shall include.

## **11. Repairs to sealed components**

- 1) During repairs to sealed components, all electrical supplies shall be disconnected from the equipment being worked upon prior to any removal of sealed covers, etc. If it is absolutely necessary to have an electrical supply to equipment during servicing, then a permanently operating form of leak detection shall be located at the most critical point to warn of a potentially hazardous situation.
- 2) Sealed electrical components shall be replaced.

## **12. Repair to intrinsically safe components**

Do not apply any permanent inductive or capacitance loads to the circuit without ensuring that this will not exceed the permissible voltage and current permitted for the equipment in use.

Intrinsically safe components must be replaced.

Replace components only with parts specified by the manufacturer. Other parts may result in the ignition of refrigerant in the atmosphere from a leak.

## **13. Cabling**

Check that cabling will not be subject to wear, corrosion, excessive pressure, vibration, sharp edges or any other adverse environmental effects. The check shall also take into account the effects of aging or continual vibration from sources such as compressors or fans.

## 14. Detection of flammable refrigerants

Under no circumstances shall potential sources of ignition be used in the searching for or detection of refrigerant leaks. A halide torch (or any other detector using a naked flame) shall not be used.

The following leak detection methods are deemed acceptable for all refrigerant systems. Electronic leak detectors may be used to detect refrigerant leaks but, in the case of flammable refrigerants, the sensitivity may not be adequate, or may need recalibration. (Detection equipment shall be calibrated in a refrigerant-free area.) Ensure that the detector is not a potential source of ignition and is suitable for the refrigerant used. Leak detection equipment shall be set at a percentage of the LFL of the refrigerant and shall be calibrated to the refrigerant employed, and the appropriate percentage of gas (25 % maximum) is confirmed.

Leak detection fluids are also suitable for use with most refrigerants but the use of detergents containing chlorine shall be avoided as the chlorine may react with the refrigerant and corrode the copper pipe-work.

NOTE Examples of leak detection fluids are:

- bubble method.
- fluorescent method agents.

If a leak is suspected, all naked flames shall be removed/extinguished.

If a leakage of refrigerant is found which requires brazing, all of the refrigerant shall be recovered from the system, or isolated (by means of shut off valves) in a part of the system remote from the leak. Removal of refrigerant shall be according to Removal and evacuation.

## 15. Removal and evacuation

When breaking into the refrigerant circuit to make repairs -or for any other purpose- conventional procedures shall be used. However, for flammable refrigerants it is important that best practice be followed, since flammability is a consideration.

The following procedure shall be adhered to:

- safely remove refrigerant following local and national regulations;
- purge the circuit with inert gas (optional for A3);
- evacuate (optional for A3);
- continuously flush or purge with inert gas when using flame to open circuit ;  
and open the circuit .

The refrigerant charge shall be recovered into the correct recovery cylinders if venting is not allowed by local and national codes. For appliances containing flammable refrigerants, the system shall be purged with oxygen-free nitrogen to render the appliance safe for flammable refrigerants. This process might need to be repeated several times. Compressed air or oxygen shall not be used for purging refrigerant systems.

For appliances containing flammable refrigerants, refrigerants purging shall be achieved by breaking the vacuum in the system with oxygen-free nitrogen and continuing to fill until the working pressure is achieved, then venting to atmosphere, and finally pulling down to a vacuum (optional for A3). This process shall be repeated until no refrigerant is within the system (optional for A3). When the final oxygen-free nitrogen charge is used, the system shall be vented down to atmospheric pressure to enable work to take place.

The outlet for the vacuum pump shall not be close to any potential ignition sources, and ventilation shall be available.

## **16.Charging procedures**

In addition to conventional charging procedures, the following requirements shall be followed.

- Ensure that contamination of different refrigerants does not occur when using charging equipment. Hoses or lines shall be as short as possible to minimise the amount of refrigerant contained in them.
- Cylinders shall be kept in an appropriate position according to the instructions.
- Ensure that the refrigerating system is earthed prior to charging the system with refrigerant.
- Label the system when charging is complete (if not already).
- Extreme care shall be taken not to overfill the refrigerating system.

Prior to recharging the system, it shall be pressure-tested with the appropriate purging gas. The system shall be leak-tested on completion of charging but prior to commissioning. A follow up leak test shall be carried out prior to leaving the site.

## 17.Decommissioning

Before carrying out this procedure, it is essential that the technician is completely familiar with the equipment and all its detail. It is recommended good practice that all refrigerants are recovered safely. Prior to the task being carried out, an oil and refrigerant sample shall be taken in case analysis is required prior to re-use of recovered refrigerant. It is essential that electrical power is available before the task is commenced.

- a) Become familiar with the equipment and its operation.
- b) Isolate system electrically.
- c) Before attempting the procedure, ensure that:
  - mechanical handling equipment is available, if required, for handling refrigerant cylinders;
  - all personal protective equipment is available and being used correctly;
  - the recovery process is supervised at all times by a competent person;
  - recovery equipment and cylinders conform to the appropriate standards.
- d) Pump down refrigerant system, if possible.
- e) If a vacuum is not possible, make a manifold so that refrigerant can be removed from various parts of the system.
- f) Make sure that cylinder is situated on the scales before recovery takes place.
- g) Start the recovery machine and operate in accordance with instructions.
- h) Do not overfill cylinders (no more than 80 % volume liquid charge).
- i) Do not exceed the maximum working pressure of the cylinder, even temporarily.
- j) When the cylinders have been filled correctly and the process completed, make sure that the cylinders and the equipment are removed from site promptly and all isolation valves on the equipment are closed off.
- k) Recovered refrigerant shall not be charged into another refrigerating system unless it has been cleaned and checked.

## 18.Labelling

Equipment shall be labelled stating that it has been de-commissioned and emptied of refrigerant. The label shall be dated and signed. For appliances containing flammable refrigerants, ensure that there are labels on the equipment stating the equipment contains flammable refrigerant.

## 19.Recovery

When removing refrigerant from a system, either for servicing or decommissioning, it is recommended good practice that all refrigerants are removed safely. When transferring refrigerant into cylinders, ensure that only appropriate refrigerant recovery cylinders are employed. Ensure that the correct number of cylinders for holding the total system charge is available.

All cylinders to be used are designated for the recovered refrigerant and labelled for that refrigerant (i. e. special cylinders for the recovery of refrigerant).

Cylinders shall be complete with pressure-relief valve and associated shut-off valves in good working order. Empty recovery cylinders are evacuated and, if possible, cooled before recovery occurs.

The recovery equipment shall be in good working order with a set of instructions concerning the equipment that is at hand and shall be suitable for the recovery of the flammable refrigerant. If in doubt, the manufacturer should be consulted. In addition, a set of calibrated weighing scales shall be available and in good working order. Hoses shall be complete with leak-free disconnect couplings and in good condition. The recovered refrigerant shall be processed according to local legislation in the correct recovery cylinder, and the relevant waste transfer note arranged. Do not mix refrigerants in recovery units and especially not in cylinders. If compressors or compressor oils are to be removed, ensure that they have been evacuated to an acceptable level to make certain that flammable refrigerant does not remain within the lubricant. The compressor body shall not be heated by an open flame or other ignition sources to accelerate this process. When oil is drained from a system, it shall be carried out safely.

- Before cleaning the dehumidifier, please turn off the machine and unplug it from the power source.
- Please do not place the machine near heat or flammable goods.
- Do not put any sticks or your fingers into the air inlet or outlet.
- Please always place the machine on a flat ground, rather than uneven or slopping ones.
- Do not spray water, insecticides or flammable liquids on the machine.
- Please do not place the machine in a confined or narrow space.
- In Dry Mode, please keep the clothes at least 15.7 inches away from the air outlet to prevent the water entering the machine to cause damages.
- Please make sure the machine power wiring is installed in accordance with national wiring rules. The power cord should be connected to a reliable external naught wire.
- The specification of the fuse: 3.15A.
- Please use this dehumidifier in an environment with the temperature range between 41°F/5°C and 95°F/35°C.
- If the supply cord is damaged, it must be replaced by the manufacturer, its service agent or similarly qualified persons in order to avoid a hazard.
- This appliance is not intended for use by persons (including children) with reduced physical, sensory or mental capabilities, or lack of experience and knowledge, unless they have been given supervision or instruction concerning use of the appliance by a person responsible for their safety.
- Children should be supervised to ensure that they do not play with the appliance.

## 02 IMPORTANT SAFETY INSTRUCTIONS

To prevent injury and property damage, the following instructions must be followed when using the dehumidifier.

### ■ Warning

- ▶ Do not place the dehumidifier near a heater.
- ▶ Do not use the dehumidifier near flammable gas or combustibles, such as gasoline, benzene, thinner, etc
- ▶ Always plug into a grounded outlet properly.
- ▶ Do not use it if the power cord is broken or damaged.
- ▶ Do not use the socket if it is loose or damaged.
- ▶ Do not modify its power cord length or share the outlet with other dehumidifiers.
- ▶ Never try to take apart or repair the dehumidifier by yourself.
- ▶ Do not place a heavy object on the power cord and make sure that the cord is not compressed.
- ▶ Do not place flower vases or other water containers on top of the dehumidifier.
- ▶ Do not operate or turn off the dehumidifier by plugging in or unplugging the dehumidifier. Use the control panel instead.
- ▶ Make sure to turn off and unplug the dehumidifier before cleaning.
- ▶ Do not clean the dehumidifier with water. If water enters the dehumidifier, turn off the dehumidifier immediately.
- ▶ Care should be taken when using the dehumidifier in a room: infants, children, and the elderly.
- ▶ Disconnect the power if strange sounds, odors, or smoke come from the dehumidifier.
- ▶ Hold the plug by the head when taking it out.
- ▶ Turn off and disconnect the power when not using the dehumidifier for a long time.
- ▶ Use a soft cloth to clean. Do not use wax, thinner, or a strong detergent.
- ▶ Be sure to replace the bucket properly after emptying it to prevent water from dripping on the floor.
- ▶ Do not climb on or sit on the dehumidifier.
- ▶ Never insert your finger or other foreign objects into grills or openings. Take special care to warn Children of these dangers.
- ▶ Children should be supervised to ensure that they do not play with the appliance.
- ▶ This appliance is not intended for use by persons (including children) with reduced physical, sensory, or mental capabilities or a lack of experience and knowledge, unless they have been given supervision or instructions for the use of the appliance by a person responsible for their safety.

## ■ How to Use a Dehumidifier Effectively

### 1. Before First Use

- ▶ The dehumidifiers may have been tilted or placed upside down during shipping. Leave the dehumidifier to stand upright for 24 hours so the oil in the compressor can settle from the move, not doing so can affect the performance or lifespan of the dehumidifier, as shown in the figure.
- ▶ Place the dehumidifier on a smooth, level floor that is strong enough to support the dehumidifier with a full bucket of water.
- ▶ The functioning temperature range is between 41°F(5°C) and 95°F(35°C).

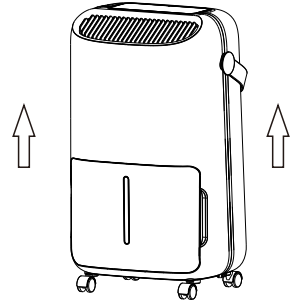

### 2. Make sure that the windows and doors are closed while the dehumidifier is operating.

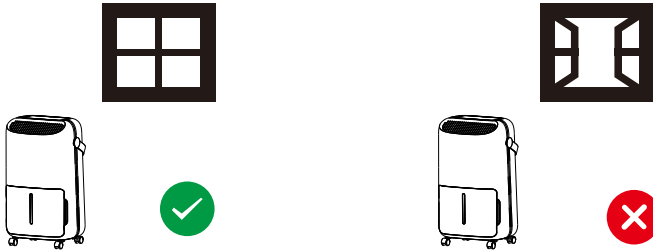

### 3. By placing the dehumidifier in the center of the room, you allow the air to circulate around the unit. Ideally, you should aim for about 18 inches of space around all sides of the unit.

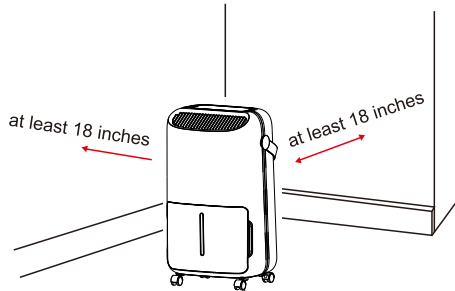

4. Don't place your dehumidifier too close to any furniture. This can further restrict the airflow around the unit.

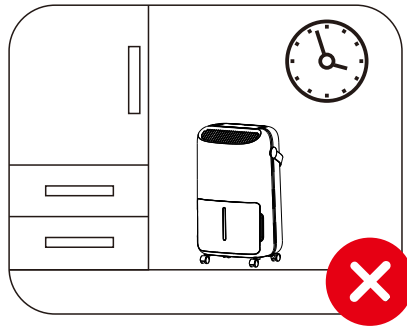

**IMPORTANT:**

The effectiveness of the dehumidifier can be influenced by different factors. One factor is the rate at which new, moisture-laden air enters the room and the amount of air circulating in and out of the area to be dehumidified. For example, if a door to a basement is constantly opened, letting new, moisture-laden air into the room, dehumidification will take longer than if the door were kept closed. If the dehumidifier is in a room with a storage closet or cabinets, it will have little or no effect on drying the inside of the storage closet or cabinets unless there is adequate circulation of air in and out of these spaces. To dehumidify these spaces, open the storage doors or cabinet doors to allow air circulation. You may find that installing a second dehumidifier may be required for larger enclosed areas.

# 03 MACHINE CONSTRUCTION

## ■ Mainframe

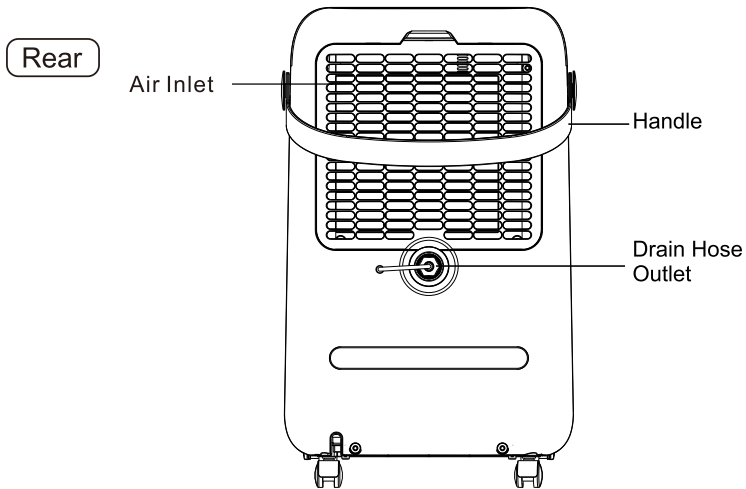
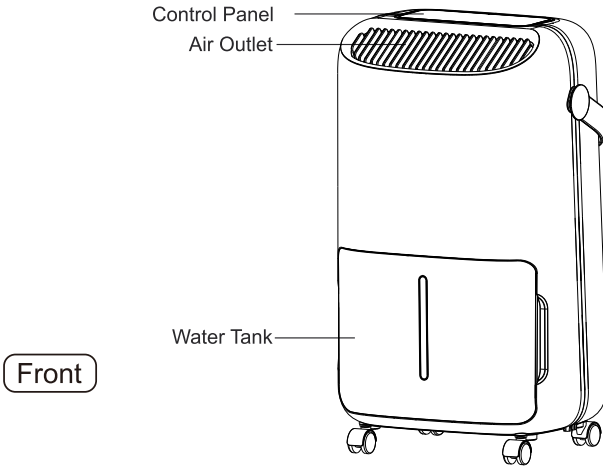





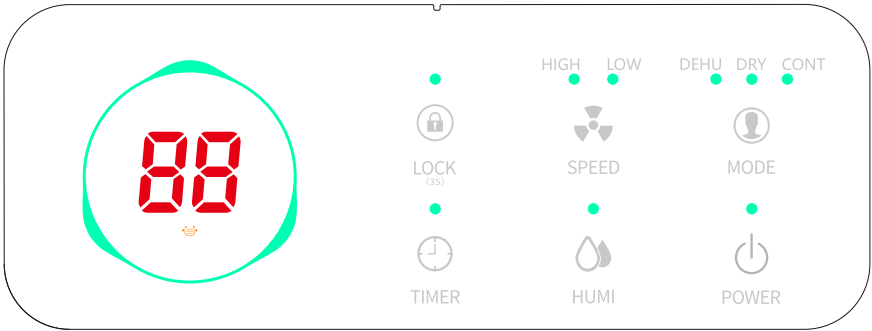

⚠ NOTE: Do not cover or block the air inlet or outlet.











# 04 OPERATION INSTRUCTION





## ■ Key Description

|   |  |   |  |
|---|--|---|--|
|  | <b>Child lock key</b><br>For activation and deactivation of the child lock function. |  | <b>Humidity key</b><br>For setting the humidity level. |
|  | <b>Fan speed key</b><br>To switch the fan speeds.                                    |  | <b>Mode key</b><br>To choose the working mode.         |
|  | <b>Timing key</b><br>To set the time on the device, the setting range is 1~24h.      |  | <b>Power button</b><br>To turn the machine on/off.     |

## ■ Function Set

- ▶ **Power button:** This button is used to turn the machine ON/OFF with the indicator light showing "ON" or "OFF" when the corresponding mode is chosen.
- ▶ **Fan speed setting:** There are two types of fan speed: high and low fan speed. When the device is turned on, press the  key to switch the fan speeds. The humidity and fan speed cannot be set in the drying mode, and the high fan speed is automatically selected.
- ▶ **Mode setting:** The device has three working modes: dehumidifying mode, drying mode, and continuous dehumidifying mode. In the power-on state, press the  button and the device will cycle through the dehumidifying, drying, and continuous dehumidifying modes. The working mode can be switched according to feature preference:
  - Dehumidification mode: humidity and fan speed can be set.
  - Drying mode: humidity and fan speed cannot be set.
  - Continuous Mode: The humidity cannot be adjusted, but the fan speed can be set.
- ▶ **Humidity setting:** In dehumidification mode (other modes are invalid), press the  key once to enter the set humidity viewing state; "  " flashes to display the set humidity value. During the flashing period of "  ", press  to set the humidity value. The setting range is 30-80% RH, which can be set cyclically. Press the  key once, and the set humidity value will increase by 5%RH. After 5 seconds of no key operation or pressing other keys, it will automatically confirm and exit, and "  " displays the current ambient humidity. When the set humidity value is 30%RH, the continuous dehumidifying mode is activated.
- ▶ **Child lock settings:** In the on or off state, long press the  button for 3 seconds to control the activation and deactivation of the child lock. After entering the child lock state, all other key operations stop working. You can only release it by long pressing the  button for 3 seconds.
- ▶ **Power-outage memory function:** If the equipment is suddenly powered off during normal operation, once it is turned back on, it will automatically return to the settings before the power off.

► **Timing settings:** If the timer is set when the device is off, the timer will be set to turn on; if it is set when the device is on, the timer will be set to turn off the device.

Press the  to set the timer. Each time you press it, the timer increases by 1h. The setting range is 1~24h, which can be set cyclically. Press and hold the  for a few seconds to continuously adjust the timer; when the timer is 00, it is invalid.

When the timer is valid, the indicator light "o" above the timing button will be on.

Press the  once, the display screen can show the remaining time on the timer, and the current humidity value will be automatically displayed after a few seconds.

► **Water full protection:** When the water tank is full, the machine will stop working, and the display screen will light up the water full indicator;

After the water in the water tank is emptied, the water full indicator on the display screen will go out, and the machine can be restarted.



**Notice:**

1. The water tank needs to be properly placed back, otherwise it will lead to water full protection.
2. During normal dehumidification, if the machine detects that the water tank is full, the compressor will immediately stop working. After approximately 3 minutes, the fan will also stop running.

► **Light status:**

Yellow Light: Humidity < 50%.

Green Light:  $50\% \leq \text{Humidity} < 70\%$ .

Red Light: Humidity  $\geq 70\%$ .

► **Display status:** After the device is powered on, in standby (shutdown) mode, only the power light is on.

Timer status indicator "o": When the timer is set and valid, it will be on. However, if the timer becomes invalid, it will turn off.

Low fan indicator "o": When the fan speed is set to low, it will be on, otherwise it will be off.

High fan indicator light "o": When the fan speed is set to high, it will be on, otherwise it will be off.

Dehumidifying mode indicator "o": When the dehumidifying mode is selected this indicator will be on, otherwise it will be off.

Drying mode indicator "o": When the drying mode is selected, it will be on, otherwise it will be off.

Continuous dehumidification mode indicator "o": When the continuous dehumidification working mode is selected, it will be on, otherwise it will be off.

Water full indicator "🚰": When the water tank is full, and about 3 minutes later, the water tank icon will appear on the display screen and light as a reminder. Otherwise, the water tank icon will disappear.

## ■ Precautions

- ▶ The dehumidifier should not operate at a humidity setting higher than the ambient humidity.
- ▶ When the water full indicator is on, pour out the water in the water tank. Then put the emptied water tank back to its original position, and the machine can continue to work.
- ▶ When the machine stops, wait at least 3 minutes before restarting to avoid damage to the compressor.
- ▶ The usable ambient temperature range is 41 ~ 95 ° F (5 ~ 35 ° C).
- ▶ When the dehumidifier is operating, the operating compressor will generate heat, which will make the room temperature higher, which is a normal phenomenon.
- ▶ When you need to move this product, please lift it facing the front of the product, as shown in Figure a.

## ■ Drain indication

Drained water can be stored in a tank or externally drained using a hose.

## ■ Use of the water tank

The water dehumidified by this machine will automatically flow into the water tank. When the water tank is full, the compressor will immediately stop running. The indicator light "o" on the power button will start flashing, and after approximately 3 minutes, the water tank icon will appear on the display screen, flashing as a reminder. The device will emit a beep sound. The fan will also stop running, and the device will automatically power off. At this point, please empty the water from the water tank.

## ■ Empty the water tank

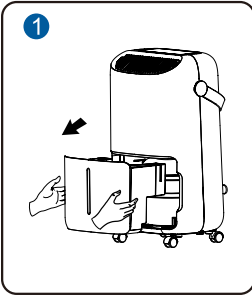

Hold the grooves on the left and right sides of the water tank with both hands at the same time, gently pull out the water tank. Please pay attention to keeping the water tank stable to avoid spillage.

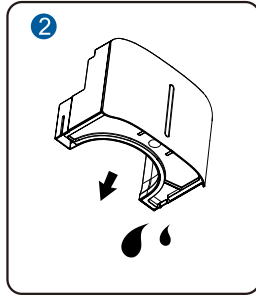

Invert the tank to empty the water.

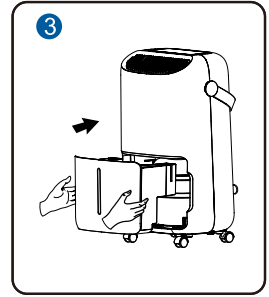

Put the tank back in place.

## ■ Continuous drainage

When you want to use this function, please unplug the power supply, pull out the rubber stopper, insert the water pipe into the continuous drain outlet, connect the power supply and start the machine. The water outlet of the water pipe should be more than 3.9inches (10cm) lower than the continuous drainage outlet, and the water pipe should not be bent to ensure smooth drainage.

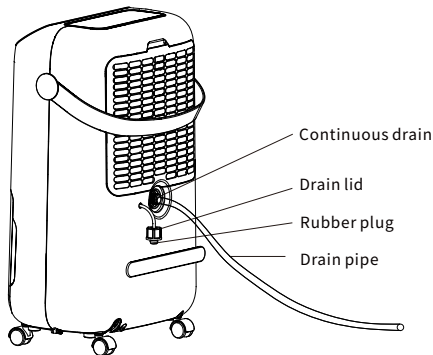

### CONTINUOUS DRAINAGE PIPE INSTRUCTIONS

Picture 1: Example of error connection

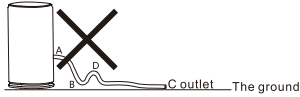

Picture 2: Example of error connection



Picture 3: Example of a correct connection

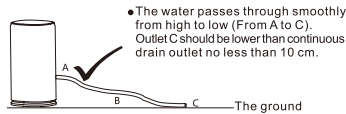

The picture is for reference only.

30701101214-05

## Filter cleaning

- ▶ Hold the filter screen as shown in the image and pull down the filter screen.
- ▶ Clean the filter: Use a vacuum cleaner to gently absorb the dust on the surface of the filter. If the filter is very dirty, wipe it with warm water and a mild detergent and dry it completely.
- ▶ As shown in the picture, insert the filter from bottom to top and insert it into the filter slot in the front shell.

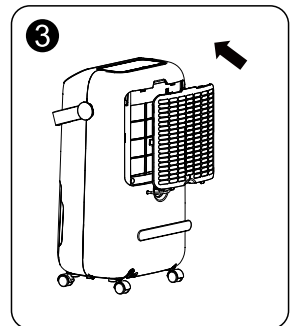
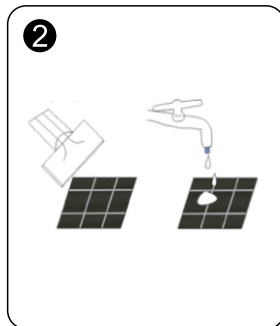
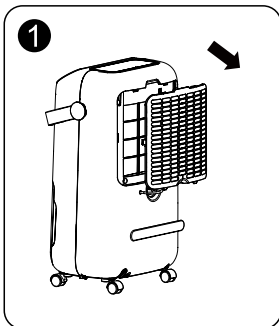

## ■ Fault Phenomenon

| Fault Phenomenon  | Cause Analysis  | Approach  |
|---|---|---|
| The machine is not running.   | Is the power cord connected properly?   | Connect the plug into the socket.   |
|   | Is the water tank in the proper position?   | Drain the water from the tank and put it back in the correct position on the body.  |
|   | Is the room temperature above 95°F (35°C) or below 41°F(5°C)?   | Because this product is not suitable for extreme environments, the machine will automatically protect and turn off, which is a normal phenomenon.   |
|   | Is the room temperature between 41°F (5°C) and 68°F(20°C)?  | The machine will defrost automatically, which is normal.  |
| Poor dehumidification efficiency  | Poor air flow?  | There should be about 7.9 inches(20cm) of space around the product.   |
|   | Is the ambient humidity too low?  | A normal phenomenon.  |
| Loud noise when running   | Air intake blocked?   | Clean any dirt from the air inlet and outlet of the product.  |
|   | Is the machine placed at an angle?  | Move the machine to a level surface.  |
| The drain hose was properly connected and Water leakage or the water still drained to the tank. | Connected to the hose without pulling out the gray rubber plug of the water outlet.                                   | Pull out the grey rubber plug of the water outlet before connecting the water pipe (please refer to the schematic diagram of continuous drainage function page in the manual for details) |
|   | The pipe is not connected properly, the other end of the pipe is blocked and the water cannot be discharged properly. | Ensure that both ends of the water pipe are unimpeded after connecting the water pipe. Keeping the water pipe in an inclined state is more conducive to gravity drainage.                 |
| The humidity displays "EF."   | Is there a fan malfunction?   | Check for any objects that may be causing the fan to jam.   |
|   |   | Repair or replace the fan.  |
| The dehumidifier is started but doesn't work.   | The tank is full or not installed properly.   | Empty the tank and reinstall it in place.   |
|   | The sensor float in the tank got stuck and didn't reposition properly.  | Push the float down to the lowest position for the correct float position.  |
|   | The dehumidifier is in the defrosting process, it is normal the compressor ceases while defrosting process.           | The defrosting process may take 15 to 20 minutes.When the defrosting is complete, the dehumidifier automatically starts to continue the dehumidification process.                         |

### Notice:

Please make sure that the air outlet is open before starting the machine, otherwise the machine will overheat. Never stop the machine directly by unplugging the power cord. If the problem persists, please shut down and unplug the power plug, Please contact Asahwo to serve [support@asahwo.com](mailto:support@asahwo.com)

# 05 SAFETY PRECAUTIONS



1. During usage, Do not place the machine on soft and uneven ground to avoid vibration or movement.



2. Do not use thin rods or hard objects to insert into the fuselage to avoid malfunction and danger.



3. When using, please keep the machine away from heat sources such as heaters and electric kettles to save electricity.



4. When using, please close all doors and windows to achieve the best dehumidifier effect.



5. Do not place items at the front and back of the machine. If ventilation is blocked, the dehumidifier's effect will be diminished.



6. In case of power failure or long-term non-use, please unplug the power cord.



7. When cleaning the fuselage, gently wipe it with a damp cloth. Do not spray water directly.



8. Do not place any objects on the fuselage.



9. Please clean the filter once every two weeks (do not use hot water above 104°F(40 °C), alcohol, gasoline or any other fluid).



10. During continuous drainage, the drainage pipe must be placed horizontally, and must not be uneven and entangled.



11. After the filter is cleaned, please do not place it in direct sunlight to dry as this may cause deformation.



12. Before moving or transporting the machine, please pour out the accumulated water in the water tank.

## 06 SPECIFICATIONS

| DEHUMIDIFIER                          |                    |
|---------------------------------------|--------------------|
| MODEL                                 | PD22SA             |
| POWER SOURCE                          | 120V~60Hz          |
| RATED POWER                           | 260W               |
| RATED CURRENT                         | 2.3A               |
| MOISTURE REMOVAL CAPACITY(65°F,60%RH) | 12.00 Pints/Day    |
| MOISTURE REMOVAL CAPACITY(80°F,60%RH) | 18 Pints/Day       |
| MOISTURE REMOVAL CAPACITY(86°F,80%RH) | 32 Pints/Day       |
| MOISTURE REMOVAL CAPACITY(95°F,90%RH) | 45 Pints/Day       |
| INPUT POWER(65°F,60%RH)               | 127W               |
| INPUT CURRENT(65°F,60%RH)             | 1.1A               |
| IEF(65°F,60%RH)                       | 1.85liters/kWh     |
| MOTOR FLA                             | 0.2 A              |
| MOTOR COMPRESSOR                      | RLA:2.0A LRA: 9.0A |
| REFRIGERANT                           | R290/50g(1.76ozs)  |
| MAXIMUM ALLOWABLE PRESSURE            | 5.5Mpa             |
| MAXIMUM ALLOWABLE DISCHARGE PRESSURE  | 2.6Mpa             |
| MAXIMUM ALLOWABLE SUCTION PRESSURE    | 1.0Mpa             |

# Limited Warranty

## Warranty and Service

If you have an issue with an ASAHWO product, please contact us at [support@asahwo.com](mailto:support@asahwo.com), and we will do our best to resolve it for you.



### Support Hours

24 Hours available

\*Please have your order number before contacting customer support.

<http://www.asahwo.com>

Product Certification  
The product is approved to leave the factory after passing the inspection.  
Production date: see the nameplate or barcode of the fuselage

A circular logo with the word "Pass" in a bold, sans-serif font across the top and "OQC" in a smaller font across the bottom.





ASAHWO

